

Light Liquid Sampler

S Y S T E M S U P P O R T M A N U A L

CPR-2S-1.5,3,5P-1A



CPR-2S-1.5,3,5P-1A

INSTRUCTION & OPERATING

MANUAL

Version: 06272005

CPR-2S-1.5,3,5P-1A TABLE OF CONTENTS

- CPR-2S-1.5,3,5P-1A Table of Contents I
- Section 1: First Things To Know 1**
 - How to Use this Manual 1
 - Typographic Conventions 1
 - Getting Help 1
 - Operation Specifications 2
 - Theory of Operation 3
 - System Accessories 3
- Section 2: System Installation 5**
 - Standard System Components 5
 - System Flow Schematic 6
 - Standard System Mounting 7
 - Standard System Connections 8
- Section 3: Filling the Pre-Charge Vessel 11**
 - Filling the Vessel 11
- Section 4: System Control & Electronics 13**
 - Overview 13
- Section 5: Programming For Proportional To Flow Operation 15**
 - Setting Operator Input Parameters 15
- Section 6: Mechanical System 19**
 - Overview 19
 - Sample Pump/Balance Valve Assembly 20
 - Accumulator Vessel 21
 - 5-Way Cross 22
 - Actuation/Mixing System 23
- Section 7: System Operation 25**
 - Preparing The System for Operation 25
 - Sample Pump Priming 25
 - Product Line Test 25
 - Portable Sample Vessel Connection 25
- Section 8: System Maintenance 29**
 - Preventative Maintenance Schedule 29
 - Recommended Maintenance Schedule 29
 - Monthly Inspection 29
 - Annual Inspection 29
 - Bi-Annual Inspection 29
 - Recommended Spare Parts List 29

Section 9: System Troubleshooting	31
How to Use This Section	31
For Additional Help	31
Step-by-Step Resolution	31
Actuation Gas Pressure	31
Actuation Gas Troubleshooting Steps	31
Electric Power	32
Electric Power Troubleshooting	32
Sample Pulse (Customer Provided)	33
Sample Pulse Troubleshooting Steps	33
Pump Performance	34
Pump Performance Troubleshooting Steps	34
Pre-Charge/Product Accumulator	35
Pre-Charge/Product Accumulator Troubleshooting Steps	35
 Appendix A: Illustrations	 37
CPR-2P Sample Pump Assembled	37
CPR-2P Balance Valve Assembly, Exploded View	38
5-Way Cross Assembly	39
Pre-Charge System	40
Product Accumulator Vessel	41
Mixing System-Accumulator	42
Pneumatic Mixing System	43
Electrical Wiring -1A	44

SECTION 1: FIRST THINGS TO KNOW ABOUT THE CPR-2

How to Use this Manual

The CPR-2S-1.5,3,5P-1A Operations Manual is a step-by-step guide containing the procedures needed to work with the CPR-2S-1.5,3,5P-1A System.

The CPR-2 System Series of samplers implement the most advanced technology available in the industry. It is recommended that the technicians working with the CPR-2 Systems study the manual prior to initiating work on the system for the first time.

Typographic Conventions

To aid in readability, this manual uses several typographic conventions. References to illustrations, photographs, and other related content will appear in *italicized text* along with the location of where to find the item in the manual. Digital versions of the manual, available in Adobe Acrobat™ PDF format, will be highlighted further in *blue italic text* indicating the copy retains a hyperlink to the referenced item.

Measurement units are listed in italic parenthesis text following their US standard equivalent. As an example, for defining a distance, 15' (*4.5 meters*), is how the text will appear throughout the manual.

Items that require action, for example the pressing of a key for programming the controller, will feature the action item in sentence case **Bold Text** followed in normal text by the item such as, the **Up Arrow** key or **Main Power** switch.

Getting Help

This manual provides solutions to typical questions about the CPR-2S-1.5,3,5P-1A system. If the answer can not be found within this manual, contact YZ Systems at:

T: 1.936.788.5593
T: 1.800.653.9435
F: 1.936.788.5720
Em: Service@yzhq.com

When calling, have this manual close at hand. Whether calling or writing, please include in your communicate the following information:

- The serial number of the LPR-2 System and the version number of this manual. The serial number is located on the enclosure of the sampler system. The version number of this manual is located at the bottom of each page.
- A description of the problem and, if applicable the actions of the technical personnel when the problem occurred.

SECTION 1: FIRST THINGS TO KNOW ABOUT THE CPR-2

Operation Specifications

Maximum Output:	6.8 gallons/day (25.3 liters/day)
Maximum Operating Pressure:	1,800 psig (124 Bar (g))
Pump Displacement:	.25 - 1.8 cc/Stroke
Operating Temp Range:	0 to 140 degrees F. (17°C to 60°C)
Sample Control:	Customer Supplied Dry Contact Pulse
Power Supply	Customer Supplied 24 VDC
Pneumatic Supply;	100 psig Instrument Quality Gas

Note: Operation at extreme temperatures may affect system performance. To enhance the performance of this system, adequate heat should be provided to maintain an operating environment above 30° F (-1° C).

SECTION 1: FIRST THINGS TO KNOW ABOUT THE CPR-2

Theory of Operation

The CPR-2 sampling systems are designed to sample crude and refined liquid hydrocarbons. Thousands of individual samples are captured and combined to develop a representative, composite sample of the flowing pipeline.

Operation of the sampling system centers around the following primary components: the Sample Pump, the Product Accumulator Vessel, and the Electronic Control System. All equipment, except the probe mounted Sample Pump is mounted on a 30" x 30" steel skid. [These components are shown in the diagrams on the following pages.](#)

The purpose of the YZ Crude & Refined Product Sampling System is to capture a representative liquid sample of the pipeline product. In order for the system to function properly, a pipeline product must be single phase, liquid product. By properly adjusting both the sample size and the sample frequency, the sample vessel will fill to 80% capacity at the end of the sample period.

The YZ crude oil and refined products system operates on a simple concept. When the system receives a closed contact signal by others, the time delay relay electronic control unit energizes the solenoid which actuates the pneumatic actuation system. Energizing the pneumatic actuation system sends a supply of actuation gas into the actuation cylinder of the sample pump, which in turn causes the pump to stroke. When the pump strokes, a small sample is displaced into the sample Accumulator Vessel. Once the actuation system is de-energized, the sample pump plunger returns to its normal position. This action captures a new sample into the pump. When the flow control system connected to the sampler, determines that it is required, the cycle begins again.

When the sample cycle is concluded, all of the sample collected is mixed, utilizing the skid mounted mixing system, and then a portion of the sample is removed from the accumulator vessel for transport to a lab, for evaluation.

After removing the remainder of the product from the accumulator vessel, the system is then ready for a new sample period.

System Accessories

- **DuraSite**, portable DOT approved constant pressure sample vessels. Available in 150, 300, 500, 800, and 1000 cc sizes.
- **KK-1, KK-2, & KK-3**: carrying cases for DuraSites that meet DOT requirements for transporting portable sample vessels.
- 1/4" stainless steel tubing **Dielectric Isolator Union**. These should be installed in every tubing line that attaches the sampler to the pipeline in any manner. For example the supply gas, product connection to the system, and differential pressure switch connections, (P/N A1-0182).

A complete line of sampling accessories ranging from sample probes to sample vessels is available through YZ. Please contact your local representative or YZ toll free at 800.344.5399. For technical support call 800.653.9435.

SECTION 2: SYSTEM INSTALLATION

Standard System Components

Standard primary components of the CPR-2S include the following:

- **System Skid, figure 1 & 2.** Houses the Sample Pump, Accumulator Vessel, Pre-charge Vessel, Five-Way Cross, and System Electronics.
- **Sample Pump/Balance Valve, figure 1.** Pneumatically actuated CPR-2P slip stream Sample Pump, mounted on the front of the sampler skid.
- **Product Accumulator Vessel, figure 1 & 2,** 1.5 gallon (5.68 Liters), 3 Gallon (11.36 Liters), 5 Gallon (18.93 Liters).
- **Pre-Charge Vessel, figure 1 & 2.** Sized to match Product Accumulator volume.
- **Five-Way Cross, figure 1.** mounts the Pressure Gage, Relief Valve, Product Isolation, and Product Removal Valves.
- **Pneumatic System, figure 2.** Provides power for the Sample Pump actuation, and the Mixing system for the Product Accumulator Vessel.

figure 1

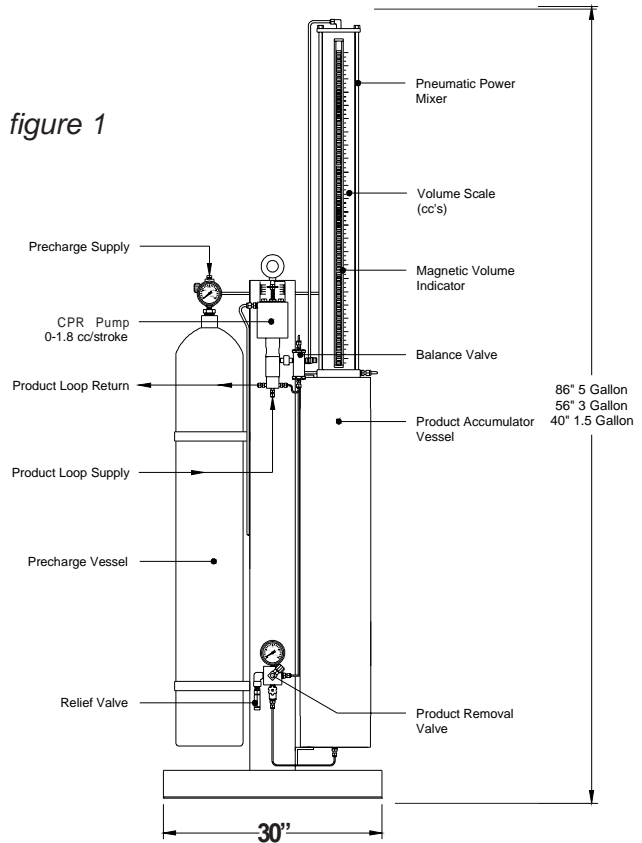
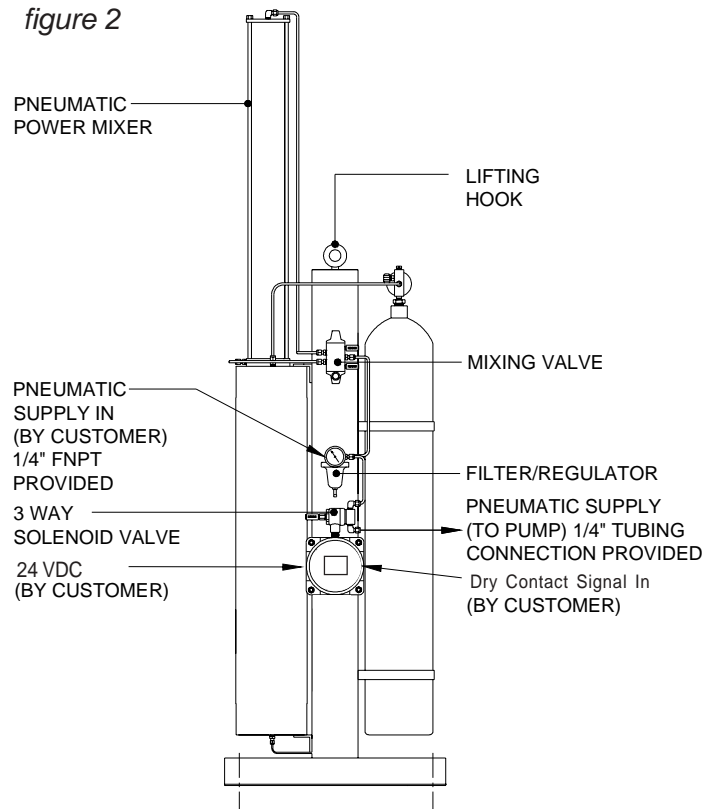

figure 2



SECTION 2: SYSTEM INSTALLATION

System Flow Schematic

figure 3

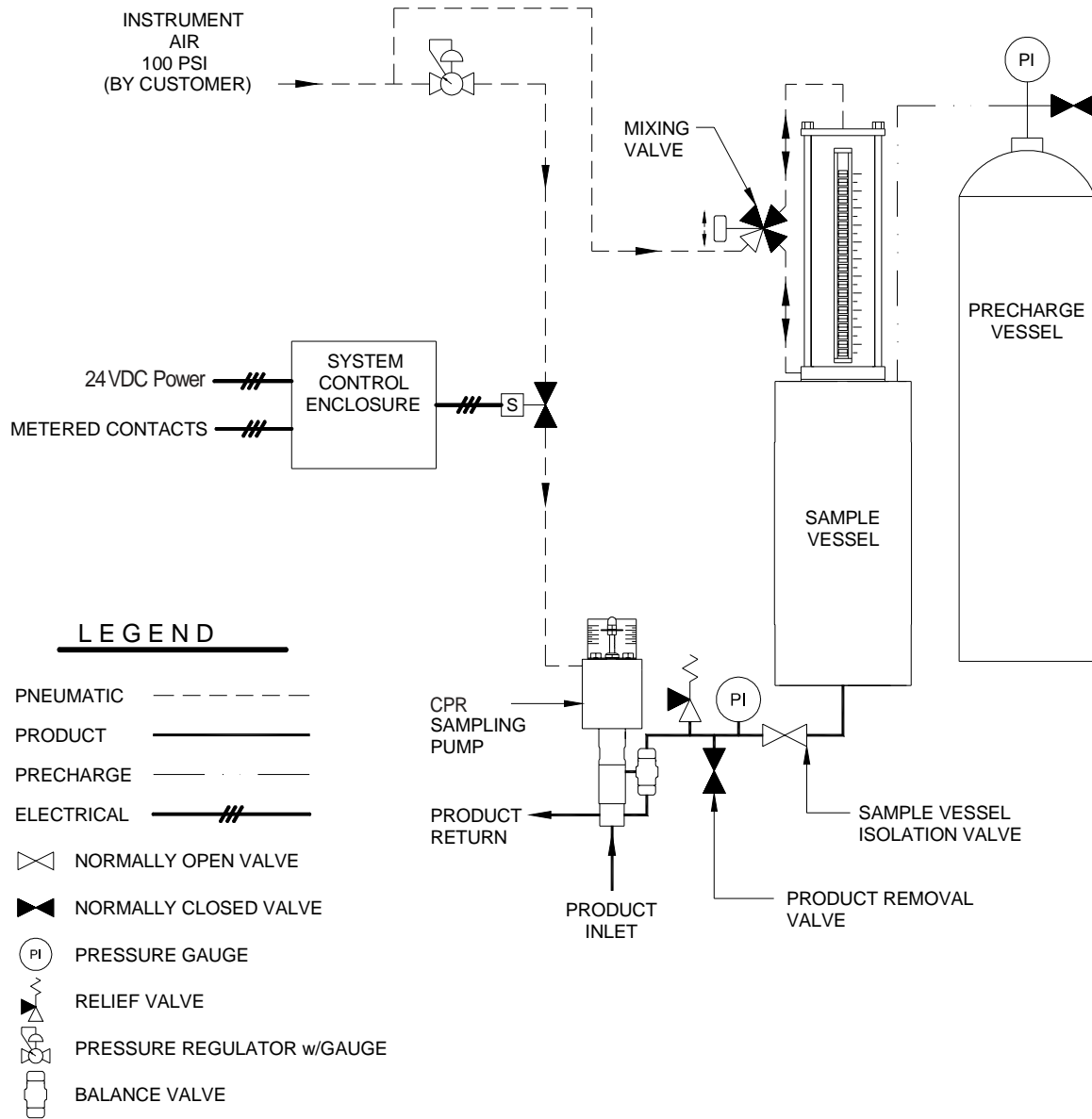

SYSTEM SCHEMATIC

SECTION 2: SYSTEM INSTALLATION

Standard Skid Mounting

1. Bolt down the system enclosure to a concrete slab using the mounting holes (5/8") provided in the bottom of each leg of the enclosure. Recommended bolt/stud sizes for mounting the enclosure is 1/2" figure 4.
2. Connect a ground wire from the grounding lug located on the enclosure leg to a properly installed ground rod, located adjacent to the system enclosure, figure 4.

figure 4

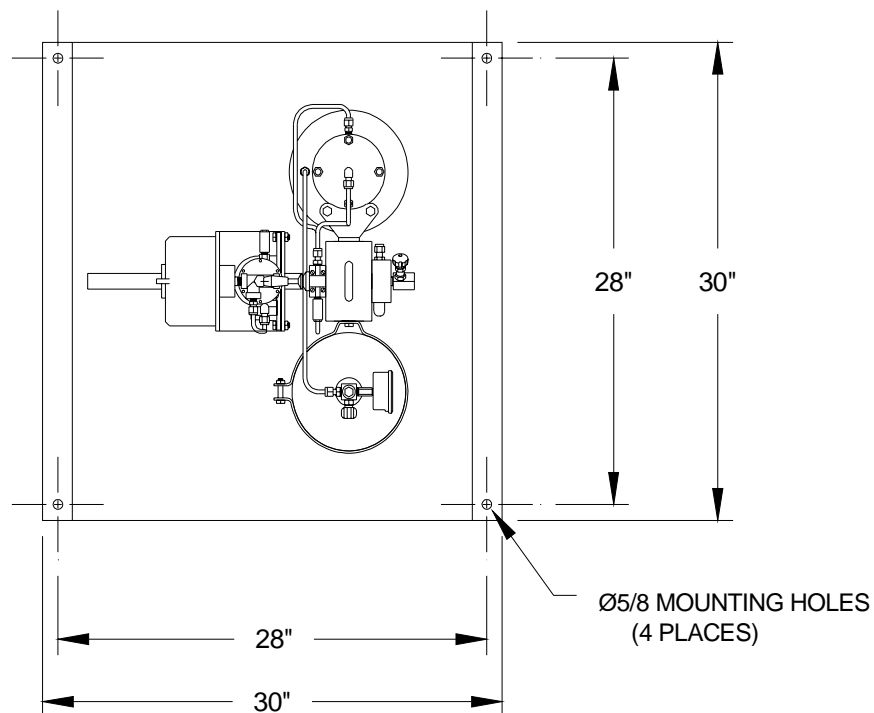

SECTION 2: SYSTEM INSTALLATION

Standard System Connections

Skid Installation

The skid should be located as close as possible to the pipeline. 1/4" stainless steel tubing should be field routed from the pipeline sample probe to the pump Product Loop Supply port tagged "product in". Likewise, 1/4" stainless steel tubing should be field routed from the pump Product Loop Return port tagged "product loop" back to a downstream port in the pipeline. These tubing lines should both incorporate a dielectric isolation fitting between the sample skid and the pipeline. Care should be taken in routing this tubing to prevent traps, long runs, etc.

CAUTION:

Excessive tubing lengths should be avoided. Installation of the sample system enclosure should be as close to the point of sample removal and the sample pump as possible. If longer tubing lengths are required consult YZ Systems Technical Services at; 800.653.9435 or 1.936.788.5593.

Electrical Connections

A 24 VDC customer supplied power supply must be connected to control the system via the side opening of the skid electrical enclosure labeled for 24 VDC. The wiring for the pulsed signal should be connected to the control the system via the side opening of the skid electrical enclosure labeled for signal in. All electrical connections are designed for 1/2" NPT conduit connections.

figure 5

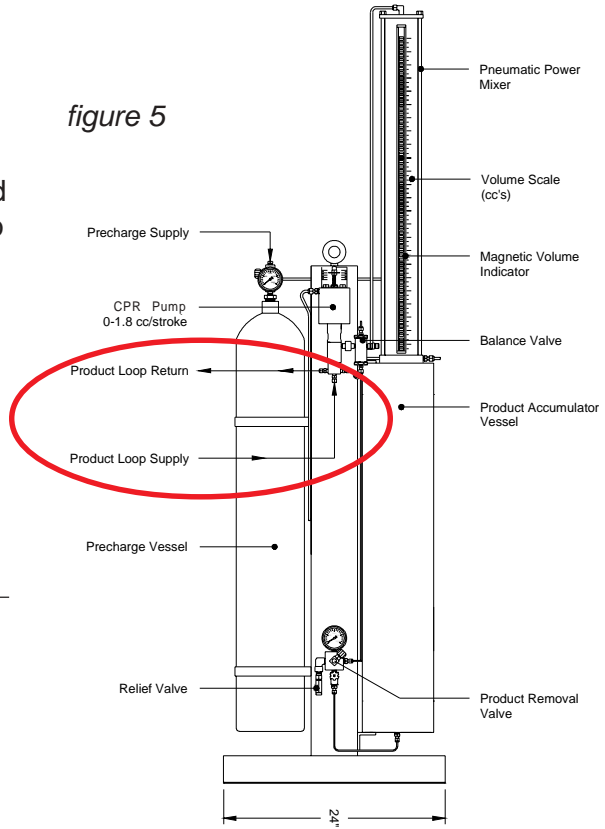
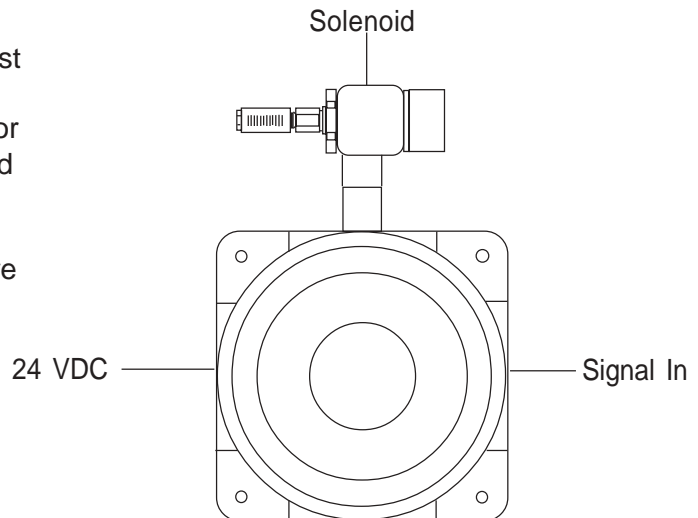

figure 6



SECTION 2: SYSTEM INSTALLATION

Pump Sample Size

The sample size of the CPR-2 is adjustable from 0.25 to 1.8 cc/stroke. The sample grab size of the pump is adjusted by loosening the 5/16" packing gland nut on top of the pump and turning the volume adjustment screw acorn nut in to decrease the sample volume or out to increase the sample volume. Once the new sample size has been set, the packing gland nut should be retightened, refer to Section 6, page 20, and Appendix, page 37 .

figure 7

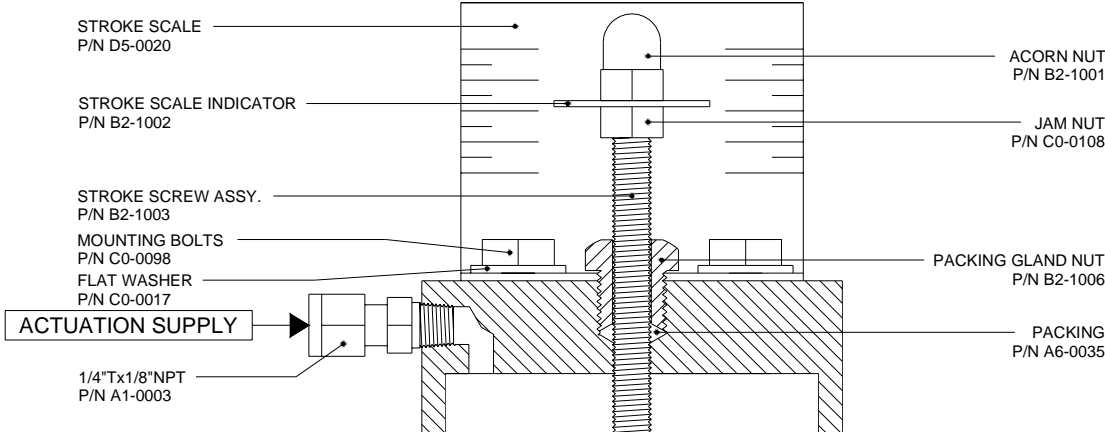

SECTION 3: FILLING THE PRE-CHARGE VESSEL

The purpose of the precharge system is to keep the sampled product in a liquid phase. This is accomplished by maintaining a precharge pressure on top of the accumulator vessel piston. The precharge vessel provides additional volume to the precharge system, which minimizes the pressure increase within the product accumulator as it fills.

Prior to placing the sampler into service, it is necessary that the precharge system be charged to a pressure at least 100 psi greater than the product vapor pressure. For example, if a product with a vapor pressure of 300 psi is being sampled, a precharge pressure of 400 psi would be required. Servicing the precharge vessel is done using the isolation valve located on top of the precharge vessel. Please note that the valve isolates the precharge system from the atmosphere, and does not separate the precharge vessel from the accumulator vessel. Also, the precharge vessel is shipped with 10 psi of blanket pressure. Normally this Pre-Charge vessel should only need to be filled one time at the installation of the sampler system, as the gas is not consumed in the sampling process.

Filling the Vessel

1. Connect the precharge gas source (normally nitrogen) to the isolation valve 1/4" NPT connection located on top of the precharge vessel, *refer to page 40*.
2. Open the isolation valve.
3. Fill the precharge vessel with gas until the pressure in the vessel is 100 to 150 psi above the vapor pressure of the product to be sampled.
4. Once the vessel is filled, close the isolation valve and remove the precharge gas source.
5. Leak test all connections between the precharge vessel and the product accumulator vessel.
6. Continue through the remaining procedures in this manual.

CAUTION:

Take necessary precautions when working with Nitrogen Vessels, as the high pressure contained within is dangerous. Additionally, all personnel should wear protective clothing, and use equipment as recommended by the manufacturer during this time. If you are uncertain about any aspect of the Nitrogen Vessel itself, you should contact the manufacturer of your Vessel prior to proceeding.

SECTION 4: SYSTEM CONTROL & ELECTRONICS

Overview

The electronic control package provided with your sampling system consists of a solid state Time Delay Relay (TDR). The TDR converts a continuous voltage signal into a 3 second voltage output to the solenoid, everytime a contact closure occurs. This 3 second duration allows sufficient time to stroke the sample pump and retrieve a single sample.

SAFETY NOTES

- Always use extreme care when performing maintenance on Sampling Systems. Always take necessary measures to assure that electrical classification in the area is considered, before, and during all repairs, and that necessary steps are taken to maintain proper electrical procedures for the classification of the area.
-

The control package requires you to provide 24 VDC at at pins #1 and #3. The wiring for the pulsed signal should be connected to the at pins #3 and #6, [refer to page 44](#). All electronics connections are housed in explosion proof enclosures and are rated for use in Class I, Division 1, Groups C and D hazardous locations.

SECTION 5: PROGRAMMING FOR PROPORTIONAL-TO-FLOW OPERATION

Setting Operator Input Parameters

The proportional to flow control function is actually performed by another customer owned flow monitoring device, like a flow computer. The set up of this other device must be done in conjunction with the set up of the sampler system in such a manner, that the proper amount of sample will be gathered during the duration of the sample cycle, and to assure that the integrity of the proportional relationship between the gathered sample, and the flowing volume in the pipeline is maintained.

The maximum amount of sample that can be safely placed in the accumulator vessel is 80% of the total vessel volume. There are two ways to arrive at the settings for the Proportional to Flow Control.

Sampler Control Set-up Option #1

This method is based on the premise that the Metered Volume per pulse value in the flow monitoring device, is already set to a predetermined value by the customer.

Calculate the pump displacement setting using the following formula:

$$\text{Pump Displacement Setting} = \frac{D}{B} \times \frac{E}{C}$$

Where, B = Average Flow rate (Gal/day or BBL/day)

C = Sample Cycle (days)

D = Metered volume per pulse (Gal/pulse or BBL/pulse)

E = 80% sample accumulator volume (cc)

For 1.5 gallon accumulators, E = 4,542 cc

For 3 gallon accumulators, E = 9,084 cc

For 5 gallon accumulators, E = 15,140 cc

refer to Example #1, figure 8, page 16.

The pump setting must be within range of 0.25 to 1.8 cc / stroke, *refer to section 2, page 9, for setting the pump displacement.*

SECTION 5: PROGRAMMING FOR PROPORTIONAL-TO-FLOW OPERATION

Example #1

figure 8

Calculating Pump Setting:

B = 2,000 Barrels of Product/Day

C = 30 Days

D = 10 Barrels/pulse

E = 9,084 cc (80% of 3 gallon vessel)

$$\frac{(10 \text{ Barrels/pulse}) \times (9,084 \text{ cc})}{(2,000 \text{ Barrels/day}) \times (30 \text{ Days})} = 1.51 \text{ cc/Stroke Pump Setting}$$

SECTION 5: PROGRAMMING FOR PROPORTIONAL-TO-FLOW OPERATION

Setting Operator Input Parameters

Sampler Control Set-up Option #2

This method is based on the idea that the operator is able to adjust the Metered Volume per pulse value in the flow monitoring device.

Calculate the Metered Volume per pulse using the following formula:

Metered Volume per pulse Setting :

Step 1.

$$\frac{A}{C} = \text{Required Sample Volume (cc) per Day}$$

Step 2.

$$\frac{\text{Required Sample Volume (cc) per Day}}{D} = \text{Number of Strokes per Day}$$

Step 3.

$$\frac{B}{\text{Number of Strokes per Day}} = \text{Metered Volume per pulse Setting}$$

Where, A = 80% sample accumulator volume (cc)

For 1.5 gallon accumulators, E = 4,542 cc

For 3 gallon accumulators, E = 9,084 cc

For 5 gallon accumulators, E = 15,140 cc

B = Average Flow rate (Gal/day or BBL/day)

C = Sample Cycle (days)

D = Pump Displacement Setting per Stroke (cc)

SECTION 5: PROGRAMMING FOR PROPORTIONAL-TO-FLOW OPERATION

Example #2

figure 9

Calculating Metered Volume per Pulse:

A = 9,084 cc (80% of 3 gallon vessel)
B = 2,000 Barrels of Product/Day
C = 30 Days
D = Pump Displacement per Stroke

$$\frac{9,084 \text{ cc}}{30 \text{ Days}} = 302.8 \text{ cc of Sample Volume/Day}$$
$$\frac{302.8 \text{ cc of Sample Volume/Day}}{1.8 \text{ cc/Pump Stroke}} = 168 \text{ Pump Strokes/Day}$$
$$\frac{2,000 \text{ BBL/Day}}{168 \text{ Pump Strokes/Day}} = 11.9 \text{ Barrels per Pulse Setting}$$

SECTION 6: MECHANICAL SYSTEM

Overview

The CPR-2S mechanical system, *figures 9 and 10* are composed of the sample pump, balance valve, accumulator vessel, and 5-way cross. Individual components of the system are shown here and described in the following pages.

figure 9

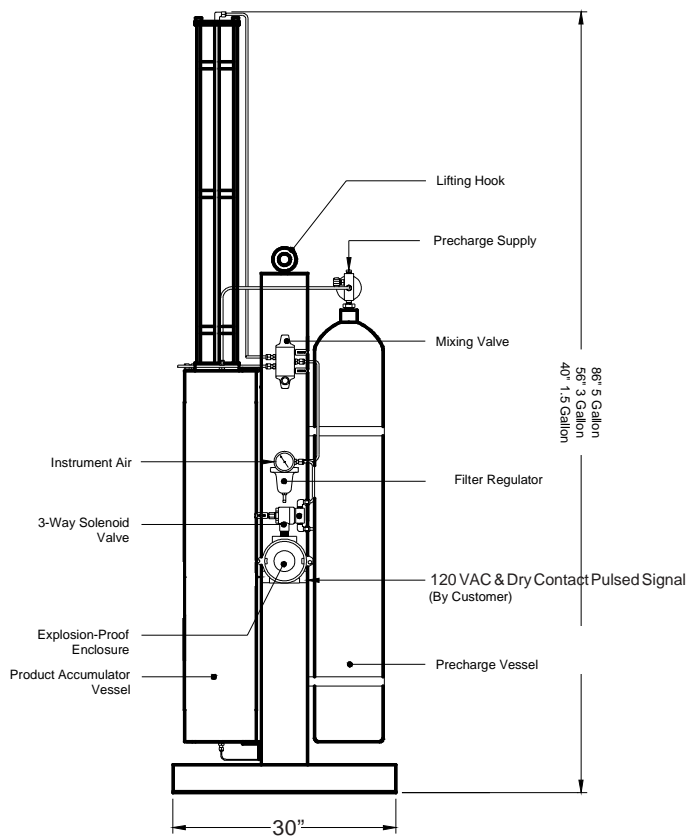
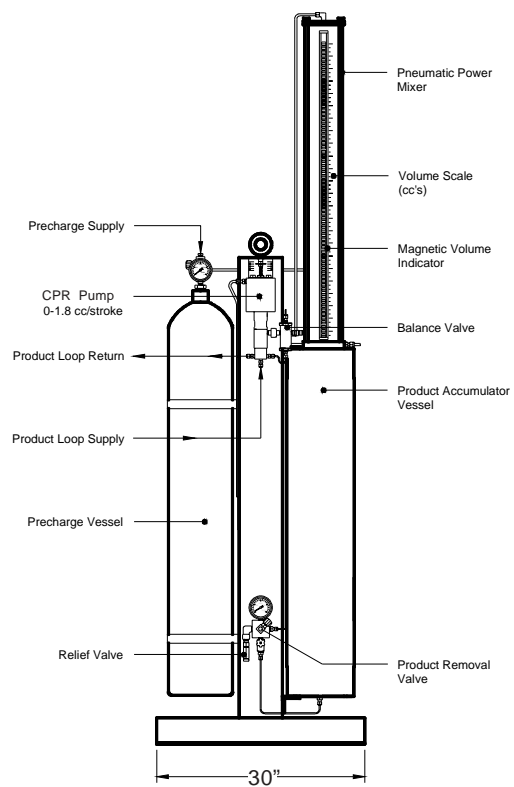

figure 10



SECTION 6: MECHANICAL SYSTEM

CPR-2S Sample Pump & Balance Valve

The CPR-2 Sample Pump, [refer to Appendix A, page 37](#), is a positive displacement plunger pump designed for slip stream attachment to the pipeline. It has an adjustable displacement of 0.25 to 1.8cc and achieves proportional-to-flow sampling through adjustment of the dry contact signal provided by others.

As the plunger returns upward after completing a stroke, the pump chamber fills with product through the inlet check valve. The inlet check valve is a ball/seat type valve designed to seat on an o-ring. The inlet check valve is spring loaded to ensure a positive seating action after every stroke. When the pump is actuated, the plunger moves downward, displacing product through the discharge check valve known as the balance valve.

The Balance Valve, [refer to Appendix A, page 38](#), automatically senses pipeline pressure and adjusts to ensure that product is not allowed to free flow to the product vessel. When the pipeline pressure is greater than the precharge pressure on the accumulator vessel, the balance valve dart is pushed up against the seat and the top head of the balance valve. As the pump strokes, the pressure created in the pump chamber forces the balance valve dart off the seat, allowing product to be pumped to the accumulator vessel. Once the pump completes its stroke, the pressure across the balance valve equalizes and the dart is returned to a sealing position by its spring.

In the event that the accumulator vessel precharge pressure is greater than the pipeline pressure, the balance valve dart and seat are pushed apart by the product pressure in the accumulator vessel. In this situation the check valve wafer located between the balance valve and the sample pump acts as a back check to prevent the escape of product previously captured in the accumulator vessel. As the pump strokes, the pressure created in the pump chamber forces the check valve wafer off the seat, allowing product to be pumped to the accumulator vessel. Once the pump completes its stroke, the pressure across the check valve equalizes and the wafer is returned to a sealing position by its spring.

SECTION 6: MECHANICAL SYSTEM

Accumulator Vessel

The YZ Product Accumulator Vessel, [refer to Appendix A, page 41](#), is designed to maintain a composite sample in the liquid phase. This is accomplished by using a free-floating piston design and an inert precharge gas system, [refer to Appendix A, page 40](#). As product is collected in the accumulator vessel, the precharge gas system maintains a constant pressure on top of the vessel piston. If this pressure is at least 100 psi above the vapor pressure of the product being sampled, the sampled product will be prevented from flashing to the vapor phase.

Product enters the cylinder through the head in the bottom of the cylinder. This head is the accumulator vessel product head. The precharge gas is communicated to the accumulator vessel through the precharge head, which is located on the top of the accumulator cylinder.

The actuator assembly is located on the top of the accumulator cylinder and serves two functions. The first is to provide mixing of the sampled product by moving the mixing disc up and down within the product portion of the accumulator cylinder. This is done by introducing hydraulic pressure to one side of the mixer piston assembly and then by applying hydraulic pressure to the opposite side of the mixer piston assembly.

The second function of the actuator assembly is to provide indication of the amount of product collected within the vessel. This is shown locally on the magnetic volume scale mounted on the actuator assembly cylinder.

SECTION 6: MECHANICAL SYSTEM

5-Way Cross

The Five-way Cross Assembly, [refer to Appendix A, page 39](#), is located on the front of the skid and includes the following items: product inlet tubing fitting, pressure gauge, relief valve, rob valve, accumulator vessel isolation valve/discharge tubing fitting, and the five-way cross.

The pressure gauge is used during normal operation to indicate the pressure within the accumulator vessel. During start-up and troubleshooting procedures it is used in conjunction with the accumulator vessel isolation valve to check pump performance.

The YZ relief valve is a reseating type valve which is factory set to relieve at 1800 psi. Also incorporated into the relief valve design is a positive indication feature which indicates that it has relieved. If the system reaches a pressure greater than the relief valve setting, the resulting release of product pushes the black relief valve indicator outside the relief valve body. This informs the system operator during his next system check that an over pressure condition has occurred. The indicator is reset by pushing it back into the relief valve body.

The rob valve is a YZ needle valve which is used to remove product from the accumulator vessel at the end of the sample period. This valve is normally closed.

The accumulator vessel isolation valve is used to isolate the accumulator vessel from the rest of the product carrying portion of the sampling system. This valve is normally open.

SECTION 6: MECHANICAL SYSTEM

Actuation/Mixing System (Pneu)

The function of the 100 psi instrument air supply is to provide an actuation power source for the sample pump and the accumulator vessel mixing system, refer to [Appendix A, page 43](#). Constructed as an integral component of the entire sampling system, the entire system is pressure tested at the factory prior to shipment.

The instrument air source is internally connected to individual components within the sampler system. These split the pneumatic source between sample pump actuation and accumulator vessel mixing. The "actuation" leg is piped to a pressure regulator (factory set at 38 psi) and on to a three-way proof solenoid valve. This solenoid valve is normally closed and is mounted in the sample system enclosure. It is opened when energized by the sampler electronic control package. Opening the solenoid valve allows pneumatic pressure to actuate the sample pump. The actuation tubing to the Sample Pump from the solenoid connection must be field installed by the customer.

The "mixing" leg of the system is tubed directly to the inlet of the accumulator mixing valve. The inlet is located on the right side of the switch. The mixing switch is a three position switch, with the center position being the off position. When the mixing switch is moved to the up position, the mixing disc is moved up in the product accumulator. Moving the mixing switch to the down position causes the product accumulator mixing disc to move down in the product accumulator. The sample in the accumulator vessel is mixed by moving the mixing handle alternately up and then down. Four or five passes through the sample should provide sufficient mixing.

SECTION 7: SYSTEM OPERATION

Preparing The System for Operation

Sample Pump Priming

Before the pump begins normal operation after initial installation or maintenance, the sample pump must be purged of all air in the sample chamber. The purge valve on the Sample Pump/Balance Valve, [refer to Appendix A, page 37](#), is used to evacuate the air from the chamber and to make sure the pump is liquid-packed. If the pump is not purged before being placed into operation, it will not function properly.

To purge the pump, open the purge valve located on the side of the CPR-2 Sample Pump/Balance Valve assembly. The product supply valve can then be opened to allow pipeline product to purge the air within the pump. Once product begins exiting the purge valve, close the purge valve. The sample pump is now ready to begin operation.

Product Line Test

Close the isolation valve located on the bottom of the Five-way Cross Assembly, [refer to Appendix A, page 39](#). Stroke the sample pump until the system pressure reaches 1800 psi on the Five-way Cross Assembly Gauge. The pressure should hold steady between pump strokes. Once the system is at 1800 psi, leak test all connections. Once the system has been tested, open the isolation valve located on the bottom of the Five-way Cross Assembly.

Sample Vessel Connection

Connect a constant pressure portable sample vessel (DuraSite) to the rob valve located on the Five-way Cross Assembly, [refer to Appendix A, page 39](#) using a short section of 1/8" or 1/4" stainless steel tubing. The portable sample vessel must also be precharged to 100-150 psi above the vapor pressure of the product, [refer to page 26](#). Open the rob valve allow product into the DuraSite as the pump takes samples. Close the rob valve and remove the sample vessel from the rob valve, at the end of each sample cycle, and replace it with a clean empty vessel for the next cycle.

SECTION 7: SYSTEM OPERATION

DuraSite Sample Vessel Connection

Purpose: The DuraSite Portable Sample Vessel permits the user to remove a liquid or gas hydrocarbon sample from a pipeline or a sampling device. This is accomplished without changing the pressure of the product or exposing it to a contaminant fluid. If properly used and maintained the DuraSite will provide many years of safe, accurate and clean sampling.

Use: The DuraSite is a very safe device to use. As with any equipment dealing with flammable products, it is mandatory that a good, thorough operator training procedure be established prior to use.

Typical use of the cylinder would be as follows:

Step 1: (In The Lab) Connect a regulated inert gas supply to the pre-charge valve. The product valve should be open. By carefully controlling the pre-charge valve and the regulator, the cylinder can be slowly charged with pre-charge gas (NOTE: This should be done slowly to prevent slamming the piston down to the opposite end). The pressure on the pre-charge pressure gauge should be brought to a reading of 10-50 psi above the expected pressure of the product in the field. Close the pre-charge valve and disconnect the gas supply. Check the pre-charge valve, relief device, and the pre-charge pressure gauge for leaks. Any leaks should be stopped before continuing. The vessel should be placed in a padded carrying case and made ready for field use.

STEP 2: FOR COLLECTION OF SAMPLE FROM COMPOSITE ACCUMULATOR VESSEL.

2a: Connect the product end of the pre-charged sample vessel to the product supply. (Sampler product removal valve)

NOTE: *the pre-charge pressure gauge reading should be greater than the product supply pressure reading. If not, repeat Step 1 above.*

2b: Once the vessel is connected to the product supply, it is necessary to vent a small amount of product prior to filling the vessel. This assures fresh product and removes any air or gas when dealing with liquids. This can be done by loosening the product purge valve a very small amount until the product is purged. After thorough purging, the product purge valve should be tightened.

2c: The product pressure gauge reading should be 10-50 psi below the pre-charge pressure gauge reading. By carefully opening the pre-charge valve, the pressure becomes equalized, then begins to drop below the product pressure. The pre-charge valve should be carefully controlled so as to not vent the pre-charge gas too fast.

2d: When the cylinder becomes a maximum of 80% full (see volume indicator), all valves should be closed. The product connection is slowly broken in order to vent any trapped product. After vessel removal, all connections should be checked for leaks and the pre-charge and product valve ports capped to prevent leakage.

2e: Pack the DuraSite in appropriate carrying case to meet D.O.T. guideline, with D.O.T. paperwork and transport to lab for analysis.

Step 3: (In The Lab) Prior to analysis, the product should be mixed. This is accomplished simply and efficiently by inverting the cylinder end-over-end, causing the mixing ball to fall through the product. Approximately 10-12 trips of the mixing ball through the product assures a homogenous solution.

Step 4: The regulated pre-charge gas should be reconnected to the pre-charge side of the cylinder. The pre-charge gas supply should remain open during analysis.

Step 5: Purging a small amount of product from the vessel removes unmixed product from the tee, relief device, gauge, etc. The unit can now be connected to a chromatograph and the product analyzed.

Step 6: After analyzing, the remainder of the product should be dumped and the vessel properly cleaned. Normal cleaning can be accomplished by rinsing the product end with a petroleum solvent and flushing with acetone. If a more thorough cleaning is required, the vessel should be disassembled.

WARNING: *A portable sample vessel should never be filled to more than 80%. This allows a 20% pre-charge cushion to absorb thermal expansion of the product.*

Shipping: Extreme care should be taken when preparing a vessel for shipment. Both valves should be capped to prevent possible leakage. The vessel should be placed in a snug-fitting, well-padded and durable case. All applicable DOT regulations should be adhered to.

SECTION 7: SYSTEM OPERATION

figure 11

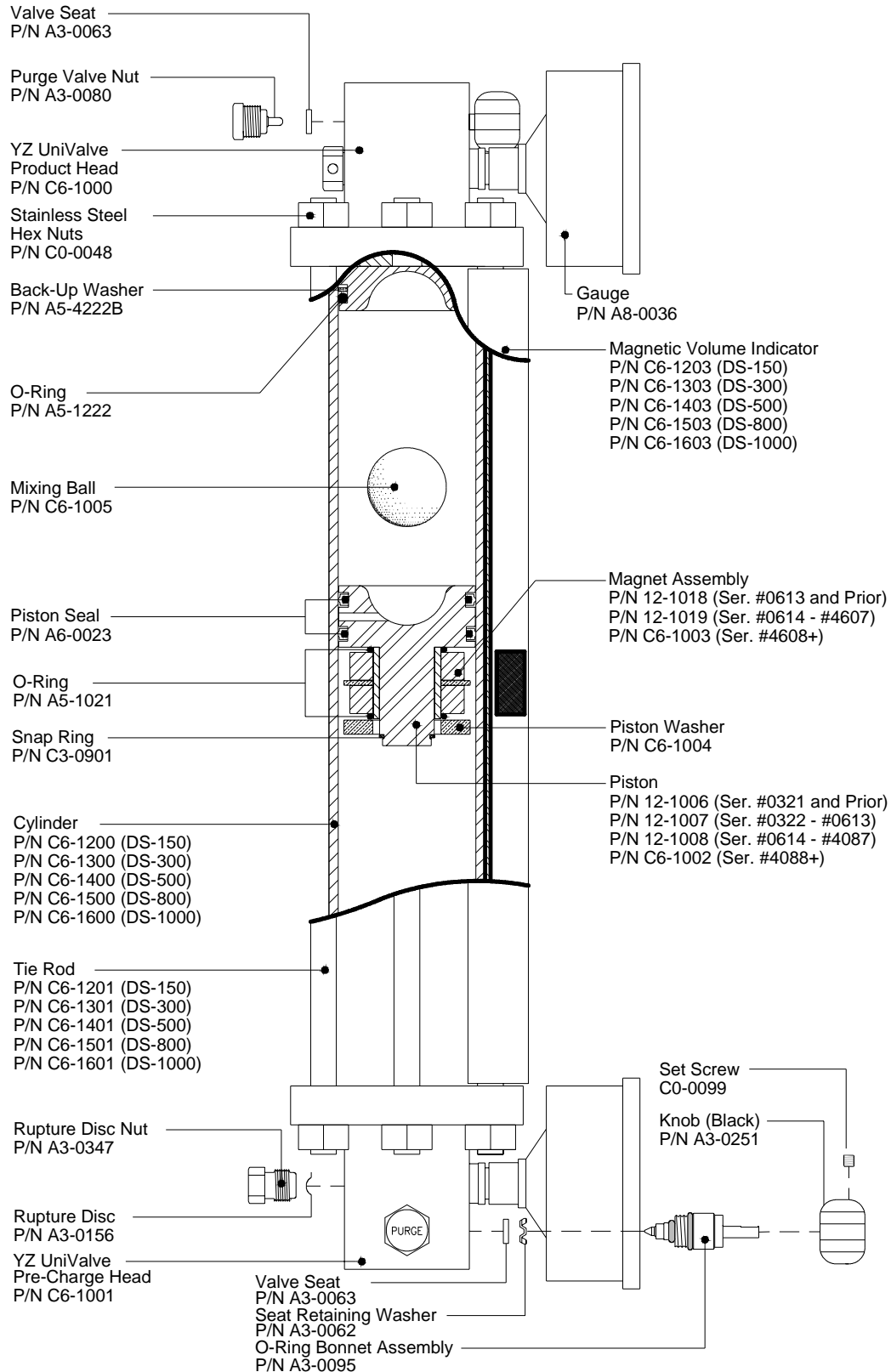

SECTION 8: SYSTEM MAINTENANCE

Preventative Maintenance Schedule

A preventative maintenance program serves to anticipate maintenance issues prior to waiting until the system requires service. Like changing the oil & filters in an automobile, by choosing to service the various parts and operation in the Sampling System at regular intervals, the technician can perform the maintenance service when desired, rather than when required, such as in the middle of night.

The key is to perform maintenance before it is required. The preventative maintenance schedule implemented should consider the application of the sampler. Many of these considerations include: the weather environment; the condition of, the actuation gas, the product condition and quality, and the pump stroke frequency. All of these issues must be considered when establishing a preventative maintenance schedule.

Recommended Maintenance Schedule Monthly Inspection

1. Verify system pressures
2. Check for leaks

Annual Inspection

1. Rebuild pump
2. Test the relief valve and service, as needed
3. Test regulators and service, as needed
4. Test the Sampler System performance

Bi-Annual Inspection

1. Perform the annual inspection listed above
2. Rebuild Accumulator Vessel

Recommended Spare Parts List

Part #	Description	Recommended Quantity
D3-0154	CPR-2P pump seal replacement kit	1
D3-0137C	Balance Valve Repair Kit	1

SECTION 9: SYSTEM TROUBLESHOOTING

How to Use This Section

The recommendations contained in this section should be used as a preliminary information resource to remedy operational issues with the CPR-2P Sampling System. It is important to read all of the definitions and notes prior to initiating work.

Each subsection contains a description of the indicators followed by a step-by-step trouble shooting procedure.

For Additional Help

Any issue that can not be resolved through the use of this reference, please contact YZ Technical Service at:

T: 1.800.653.9435
T: 1.936.788.5526, International Calls
F: 1.936.788.5720
Em: Service@yzhq.com

SAFETY NOTES

- Always use extreme care when performing maintenance on Sampling Systems. Always take necessary measures to assure that electrical classification in the area is considered, before, and during all repairs, and that necessary steps are taken to maintain proper electrical procedures for the classification of the area.
 - Take special care when disconnecting any fitting, to assure that product and/or pressure will not be released when the connection is broken. This system may contain liquid and/or gas at high pressures.
-

Step-by-Step Resolution

Using a step-by-step method to resolve issues on the Sampling System will reduce maintenance time and assist in returning the system to service quicker.

The following represent the recommended chronology to resolve issues:

Resolve issues to the following order:

- a. *Actuation Gas Pressure*, [page 31](#)
- b. *Electrical Power*, [page 32](#)
- c. *Sample Pulse*, [page 33](#)
- d. *Pump Performance*, [page 34](#)
- e. *Pre-Charge Pressure /Product Accumulator Vessel* , [page 35](#)

Actuation Gas Pressure

This section should be used to troubleshoot sampler performance, when the Sample Pump will not actuate, and/or when the pneumatic power mixing system on the Accumulator Vessel will not function.

Actuation Gas Troubleshooting Steps

1. Verify the supply gas valves, and regulators supplying gas to the sampler system are properly functioning, and adjusted.
2. Disconnect the Pneumatic Supply connection at the top of the Sample Pump.
 - a. There should NOT be any gas pressure present. Gas pressure should be present for ONLY 3 seconds each time a sample pulse is received by the sample systems from the flow monitoring device, that signals the sampler when to take a sample.
 - b. Initiate a sample with the flow monitoring device pulse, and observe to see if a 3 second burst of gas is expelled from the connection loosened in step 2 above.

SECTION 9: SYSTEM TROUBLESHOOTING

- c. If a 3 second burst of gas is expelled from the connection loosened in step 2, the actuation system to the pump is functioning properly. Reconnect the Pneumatic Supply connection to the top of the Sample Pump. Proceed to pump performance troubleshooting, if the problem seems to be with your pump, or proceed to step 3, if you are having difficulties with the power mixing of your sample system.
3. Disconnect the tubing at the top of the Actuator Head of the Product Accumulator vessel. There should not be any pressure there until the Mixing Valve is placed in the down mixing position.
 - a. If gas is flowing continually when this line is disconnected, the Mixing Valve should be repaired, or replaced.
 - b. If gas does not flow to the loosened connection when the Mixing Valve is actuated to the down position, try moving the valve to the up position, and see if you get gas flow at the loosened connection. If you still have no gas flow to the loosened connection, the Mixing Valve should be repaired, or replaced.
 - c. If gas does flow properly, to the loosened connection, when the Mixing Valve is placed in the down mixing position, check the vent/muffler on the Mixing Valve to see if it may be stopped up. Clean or replace the vent/muffler as required.

Electrical Power

IMPORTANT NOTE:

All electronics are housed in explosion proof enclosures and are rated for use in Class I, Division 1, Groups C and D hazardous locations.

The 24 VDC power supply to the sampler must be properly connected and supplying power to the sample system, before it can be expected to perform. Often electrical storms, or other electrical surges that occur at the sampler site may cause interruption of the power supply to the sampler. The power is used to drive the solenoid for a duration of 3 seconds each time a sample is called for by the flow monitoring device connected to the sampler system. Electrical power troubleshooting will include steps to assure the 24 VDC power is actually getting to the solenoid for the required duration, and that the solenoid is activating the sample pump. The typical symptom to lead a technician to this step would be that the sample pump is not being actuated when a pulse from the flow monitoring device sends a dry contact sample pulse to the sampler.

Electrical Power Troubleshooting Steps

CAUTION:

Prior to opening the electrical enclosure be sure to disconnect all power and pulse connections at the safe end of wiring or perform test to assure the area of the enclosure is safe to open the enclosure.

1. Verify the 24 VDC power is actually reaching the TDR in the Sample System electrical enclosure.
 - a. Test for continuous 24 VDC at the TDR by connecting your DC Voltmeter to the TDR terminal pins #1 and #3. (Pin #1 should be the Negative connection, and pin #3 should be the Positive connection), [refer to electrical wiring document, on page 44.](#)

SECTION 9: SYSTEM TROUBLESHOOTING

- b. If there is not 24 VDC continuous power to the TDR, check the breaker, and DC wiring back to the DC source. Repair any loose or broken wires, reset or replace circuit breaker as required.
2. The next Electrical Power test is to see if the TDR functions properly when a dry contact pulse is applied
 - a. Once continuous 24 VDC power is verified at pins #1 and #3 on the TDR, (step #1 above); Connect your DC Voltmeter to the TDR terminal pins #2 and #3 (Pin #2 should be the Negative connection, and pin #3 should be the Positive connection), [refer to electrical wiring document, on page 44](#). This should be a pulsed 24 VDC with a 3 second duration ONLY when the TDR is activated, by the dry contact pulse from your flow monitoring equipment.
 - b. If the flow monitoring device can not be utilized to send a test pulse at this time, you may be able to create a test pulse.

CAUTION:

These connections carry 24 VDC power.

- Connect a normally open switch that is capable of creating a dry contact closure, and rated for the voltage present, to pins #3 and #6 on the TDR, [refer to electrical wiring document, on page 44](#) Close the switch momentarily, while your DC voltmeter is connected as in troubleshooting step 2a.
3. The next electrical power test has to do with the dwell time of the TDR. If the test #1 and #2 have not resolved your problem, the delay resistor on the TDR may have been damaged. The resistor is connected to pins #4 and #5 on the TDR, [refer to electrical wiring document, on page 44](#). It should be a 330 K. 1 Watt resistor, YZ P/N G1-0024.
 4. The final step in troubleshooting the electrical power for the sampler, would be to replace the TDR itself. It is available from YZ Systems by ordering P/N E0-6007.

Sample Pulse

The sample pulse is actually a contact closure that allows one leg of the 24 VDC power in the TDR to connect to another pin of the TDR causing the Timed Delay circuit to energize, thus sending a 24 VDC signal to the solenoid for 3 seconds. The origin of this contact pulse is in the flow monitoring equipment, that is not actually a part of the sampler system; therefore troubleshooting will be limited to verifying that the sampler system does respond properly when an appropriate pulse is generated.

Sample Pulse Troubleshooting Steps

CAUTION:

Prior to opening the electrical enclosure be sure to disconnect all power and pulse connections at the safe end of wiring or perform test to assure the area of the enclosure is safe to open the enclosure.

1. 1st you should determine if the TDR functions properly when a dry contact pulse is applied.
 - a. Connect your DC Voltmeter to the TDR terminal pins #2 and #3 (Pin #2 should be the Negative connection, and pin #3 should be the Positive connection), [refer to electrical wiring document, on page 44](#). This should be a pulsed 24 VDC with a 3 second duration ONLY when the TDR is activated, by the dry contact pulse.
 - b. Disconnect the flow monitoring device, by removing wires from the TDR pins #3 and #6, [refer to electrical wiring document, on page 44](#).

CAUTION:

These connections carry 24 VDC power.

SECTION 9: SYSTEM TROUBLESHOOTING

- c. Connect a normally open switch that is capable of creating a dry contact closure, and rated for the voltage present, to pins #3 and #6 on the TDR, refer to [electrical wiring document, on page 44](#). Close the switch momentarily, while your DC voltmeter is connected to the TDR terminal pins #2 and #3 (Pin #2 should be the Negative connection, and pin #3 should be the Positive connection), refer to [electrical wiring document, on page 44](#). Your volt meter should show a pulsed 24 VDC with a 3 second duration ONLY when the TDR is activated, by the dry contact closure created above. If you do not see the 3 second pulse of electricity, go through the Electrical Power trouble shooting steps again. If you do get the 3 second pulses of electricity, proceed to checking for a broken wire between the TDR and the Flow Monitoring Equipment, or begin troubleshooting the Flow Monitoring Equipment.
3. The next step, if the pump did not pass the test in step 2, is to verify that the pump is fully liquid packed with liquid product to be pumped. The Sample Pump must be purged of all air in the sample chamber, before it can pump liquid product. The purge valve on the sample pump is used to evacuate the air from the chamber and to make sure the pump is liquid-packed. If the pump is not purged properly, it will not function properly.
 - a. Open the purge valve located on the right side of the PNR-2 sample pump/balance valve.
 - b. Next open the product supply valve to allow pipeline product to purge the air within the pump.
 - c. Once product begins exiting the purge valve, close the purge valve. The sample pump is now ready to begin operation. Perform pump test #2 again. If your product is not consistently in a single phase liquid state the pump will vapor lock again, and repriming will be necessary, repeatedly, till the phase condition of the product is resolved.

Pump Performance

There are many factors that affect pump performance. Some are within the pump, while others are outside factors that affect pump performance.

Pump Performance Troubleshooting Steps

1. Actual performance of the Actuation Gas, and Electrical Power issues should have already been dealt with, If not , perform those troubleshooting steps before proceeding to step 2.
2. Close the isolation valve located on the bottom of the Five-way Cross Assembly. Stroke the sample pump while observing the pressure reading on the Five-way Cross Assembly Gauge. The system pressure should steadily build to 1800 psi . The pressure should hold steady between pump strokes. Once the system is at 1800 psi, leak test all connections. Once the system has been tested, open the isolation valve located on the bottom of the Five-way Cross Assembly. Completion of this test verifies the pump performance is O.K.
4. If during the pump troubleshooting step 2, you observed the pressure on the Five-way Cross Assembly Gauge jumping from pipeline pressure to a higher pressure, during the pump stroke, but immediately returning to pipeline pressure after the stroke, the Balance Valve Assembly should be rebuilt using a YZ Repair Kit P/N D3-0137.
5. If during the pump troubleshooting step 2, you observed the pressure on the Five-way Cross Assembly Gauge build steadily to pipeline pressure, then stop building at pipeline pressure, the Sample Pump inlet check is not holding. Typically installing a YZ Repair Kit P/N D3-0152, will resolve this situation.

SECTION 9: SYSTEM TROUBLESHOOTING

Pre-Charge/ Product Accumulator

The Product Accumulator works in conjunction with the Pre-Charge Vessel to maintain the integrity of captured sample in the sampler system. The Product Accumulator Vessel may be repaired on site, but requires some special tools to do so, and it is recommended that if this vessel needs service, you should contact YZ Systems Technical Service @ 1.936.788.5720 to obtain a Return Authorization Number to return the Product Accumulator Vessel to YZ for reconditioning. The pre-charge vessel pressure must remain at a pressure that exceeds the critical vapor pressure of the product being sampled. A typical pressure setting should be 100 PSI over the pipeline pressure.

Pre-Charge/Product Accumulator Troubleshooting Steps

1. If the charge in the vessel is low, recharge it to the proper pressure, by connecting an external source of inert gas to the Pre-Charge Isolation Valve, and open the valve until the Pre-Charge Vessel pressure is once again at the desired pressure.
2. Close the Pre-Charge Isolation Valve.
3. Disconnect the external source of inert gas.
4. Wrap a 1/4" MNPT plug with TFE tape, and install it in the Pre-Charge Isolation Valve.
5. Use liquid soap to leak test all connections on the Pre-Charge Vessel, Pre-Charge Isolation Valve, Tubing to the Accumulator Vessel, and Pre-Charge connection to the Accumulator Vessel. Fix any leak detected.
6. If no leaks were found in step 5, look at the most recent analysis report on product taken from this sampler, to see if an abnormal amount of inert gas of the type used for Pre-Charge was present in the sample. If Pre-Charge gas is found in the sample, contact YZ Systems Technical Service @ 1.936.788.5720 to obtain a Return Authorization Number to return the Sample Accumulator Vessel to YZ for reconditioning.

APPENDIX A: ILLUSTRATIONS

CPR-2P Sample Pump, Assembled

Figure 12

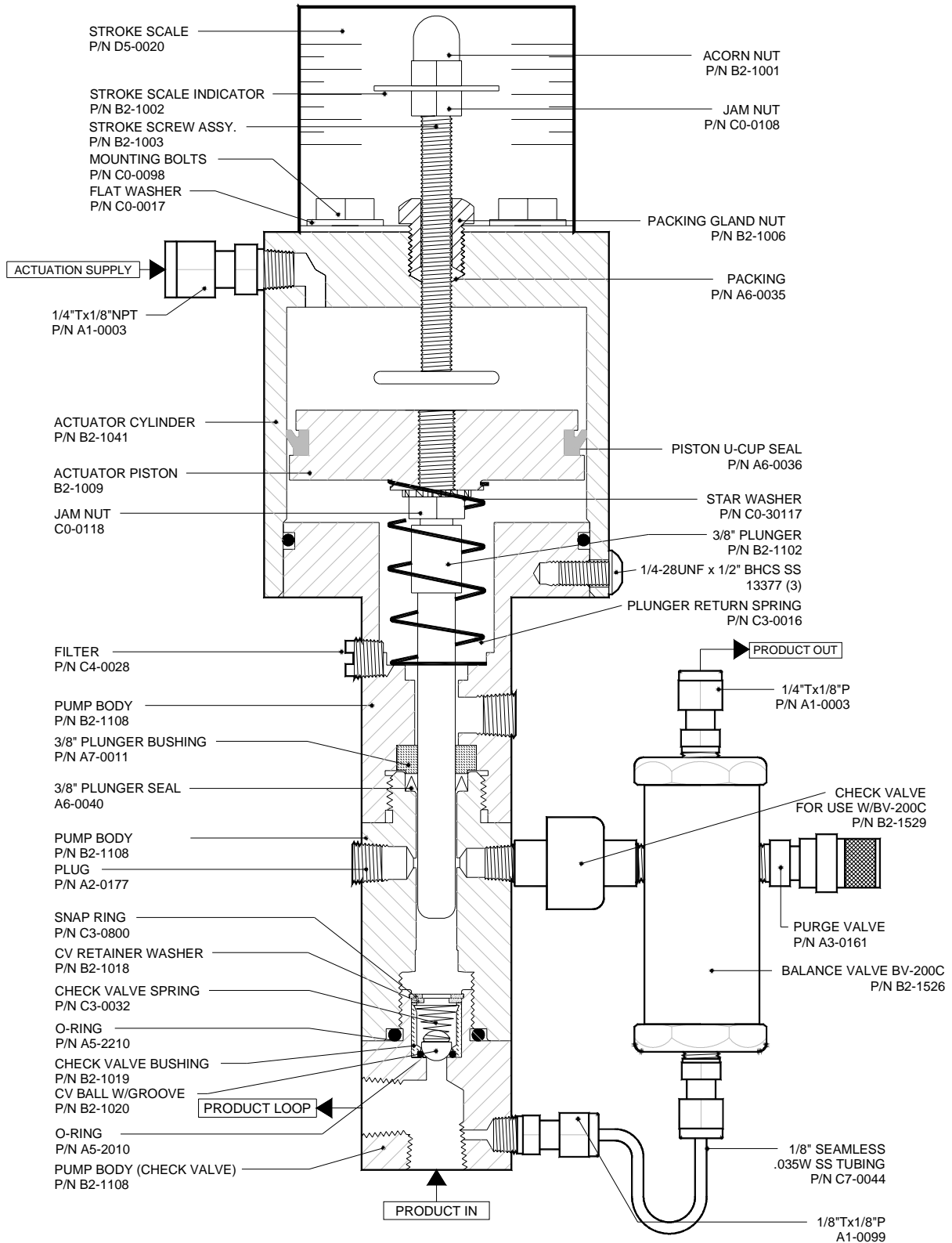

APPENDIX A: ILLUSTRATIONS

CPR-2 Balance Valve, Exploded View

Figure 13

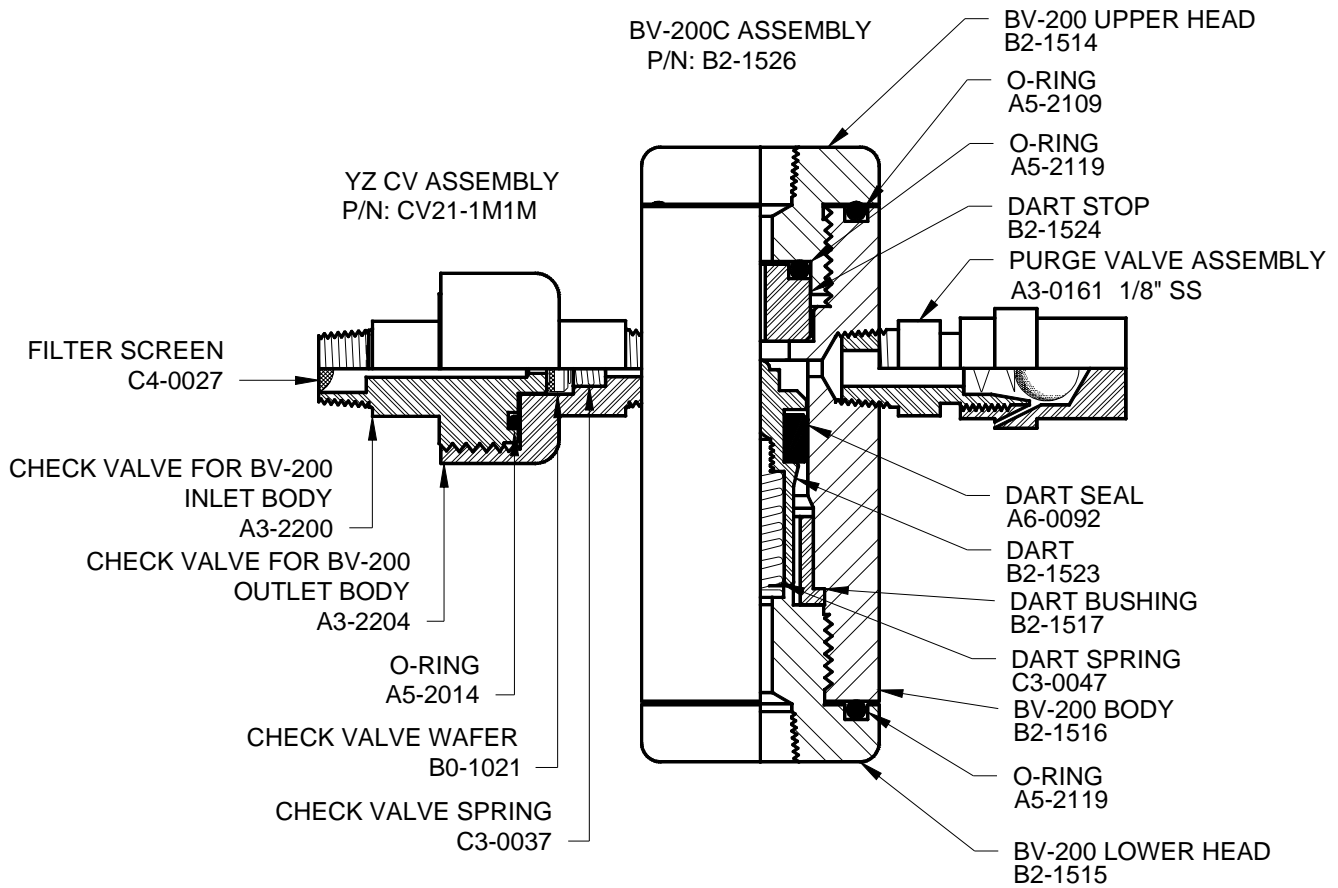

APPENDIX A: ILLUSTRATIONS

5-Way Cross Assembly,

Figure 14

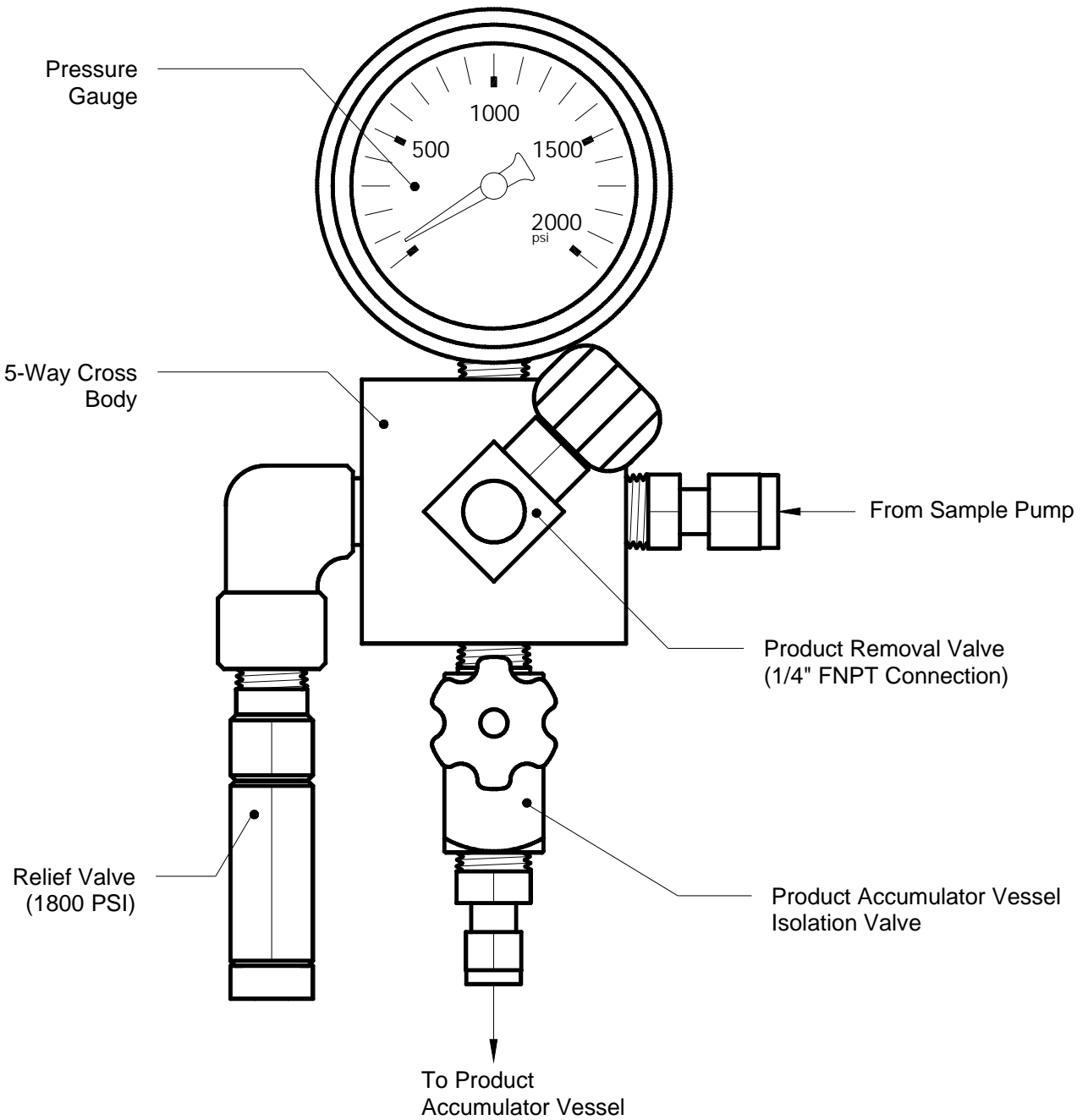

APPENDIX A: ILLUSTRATIONS

Pre-Charge Assembly,

Figure 15

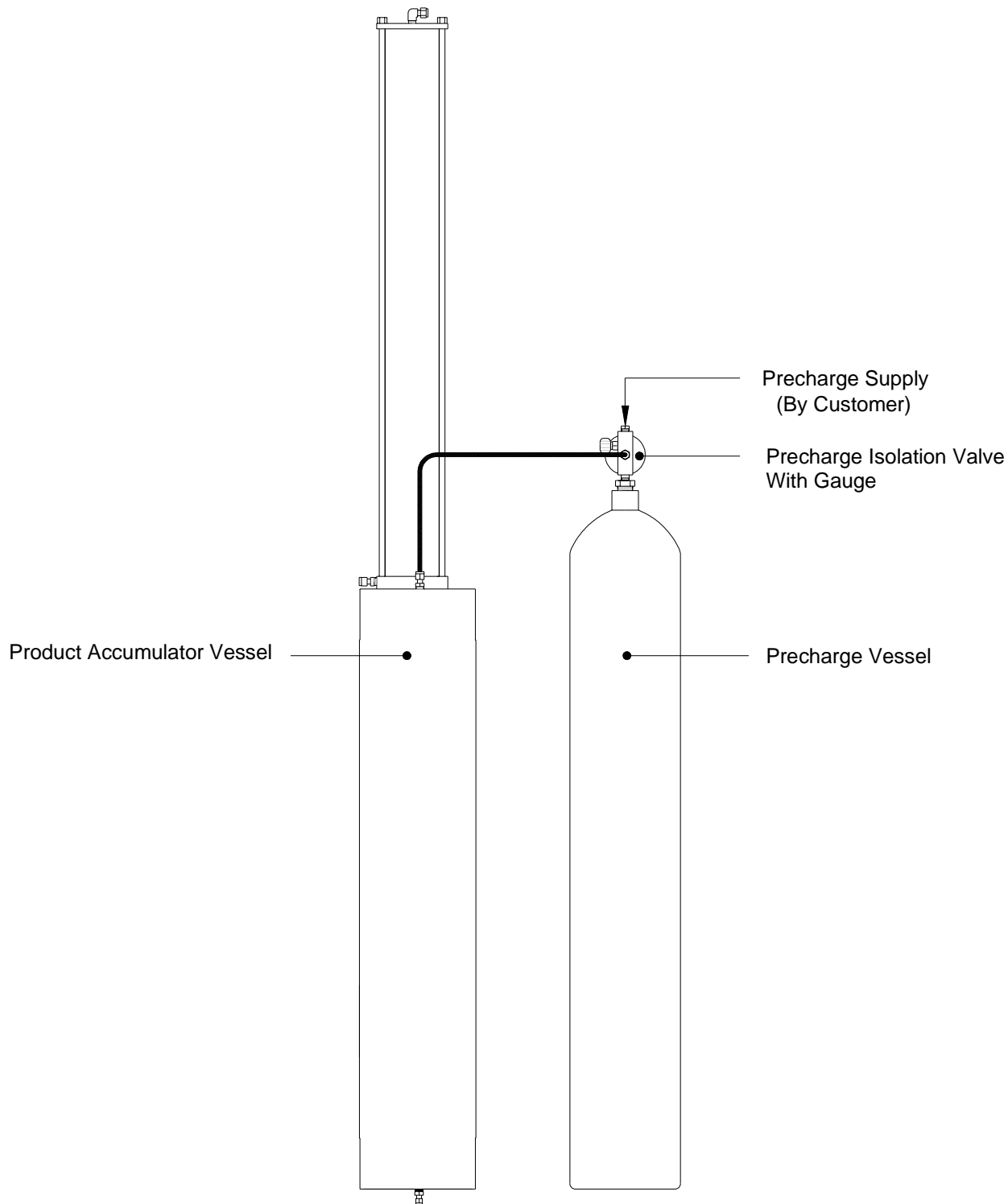

APPENDIX A: ILLUSTRATIONS

Accumulator Vessel,

Figure 16

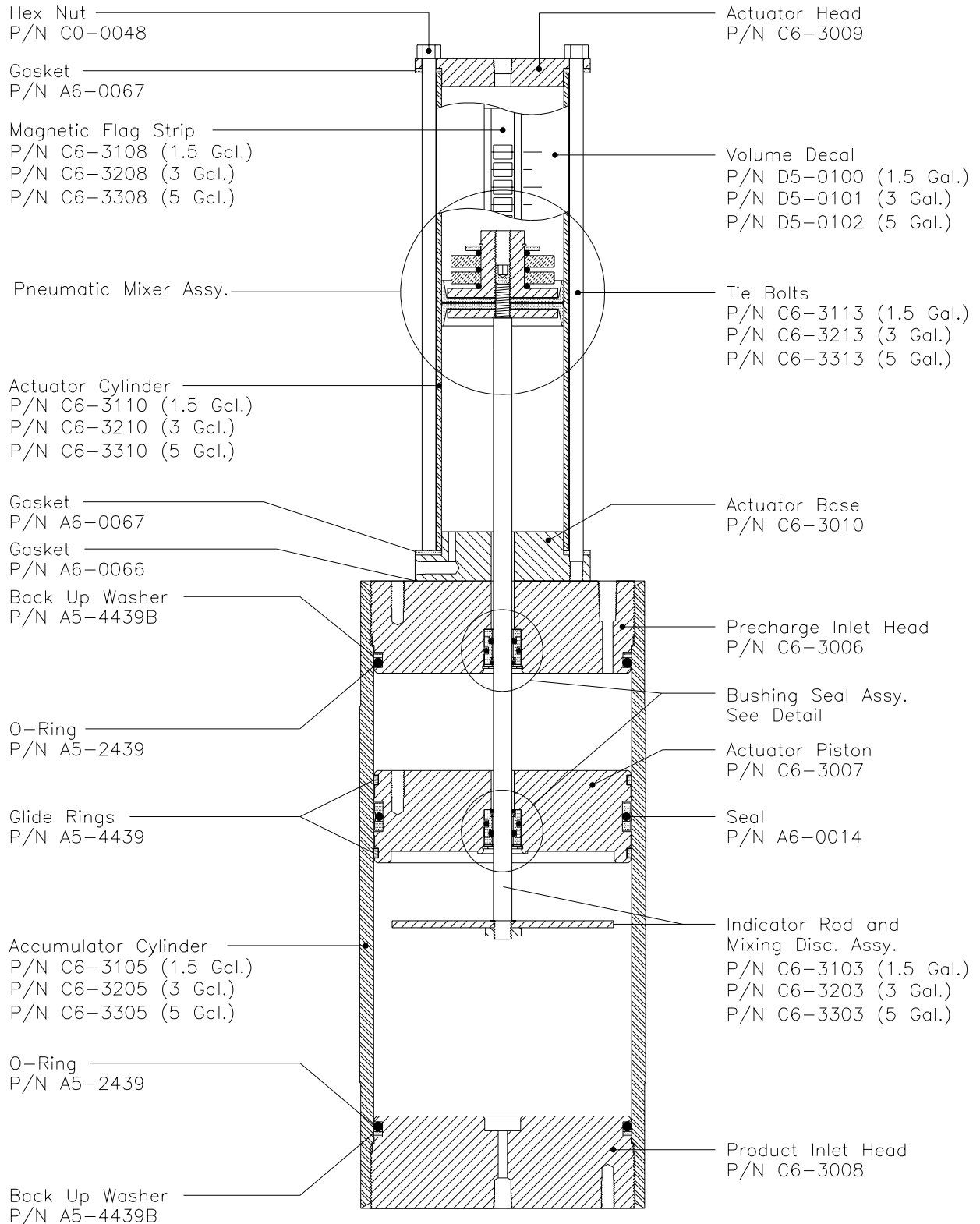

APPENDIX A: ILLUSTRATIONS

Accumulator Vessel,

Figure 17

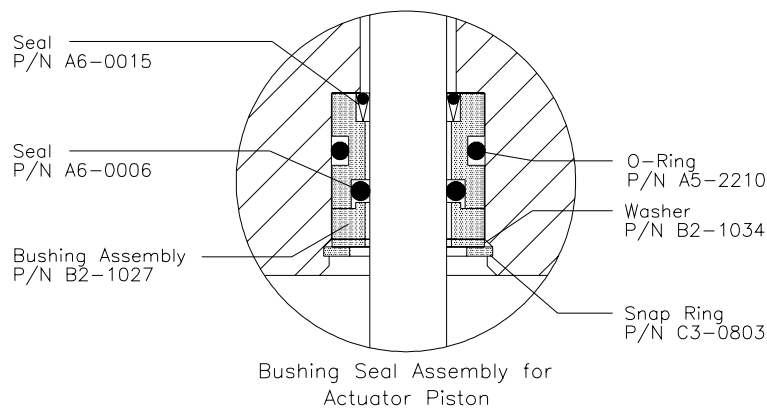
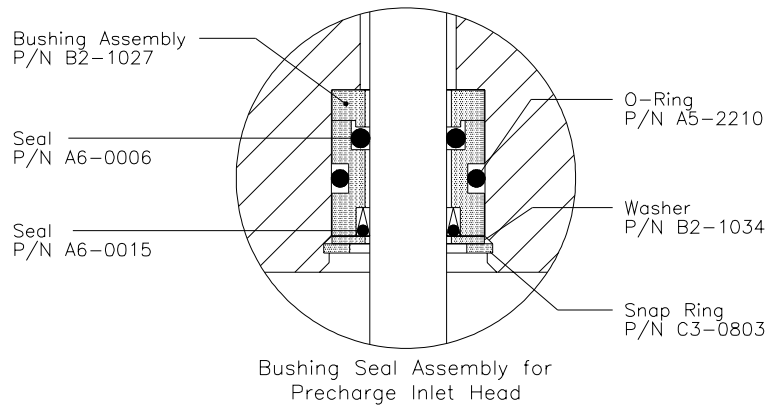
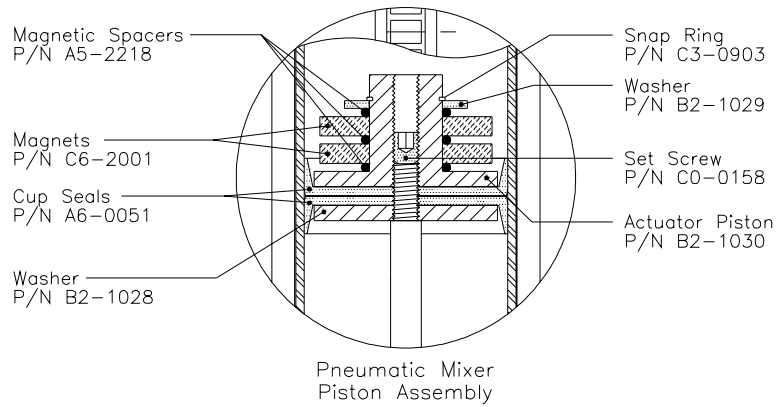

APPENDIX A: ILLUSTRATIONS

Pneumatic Mixing System,

Figure 18

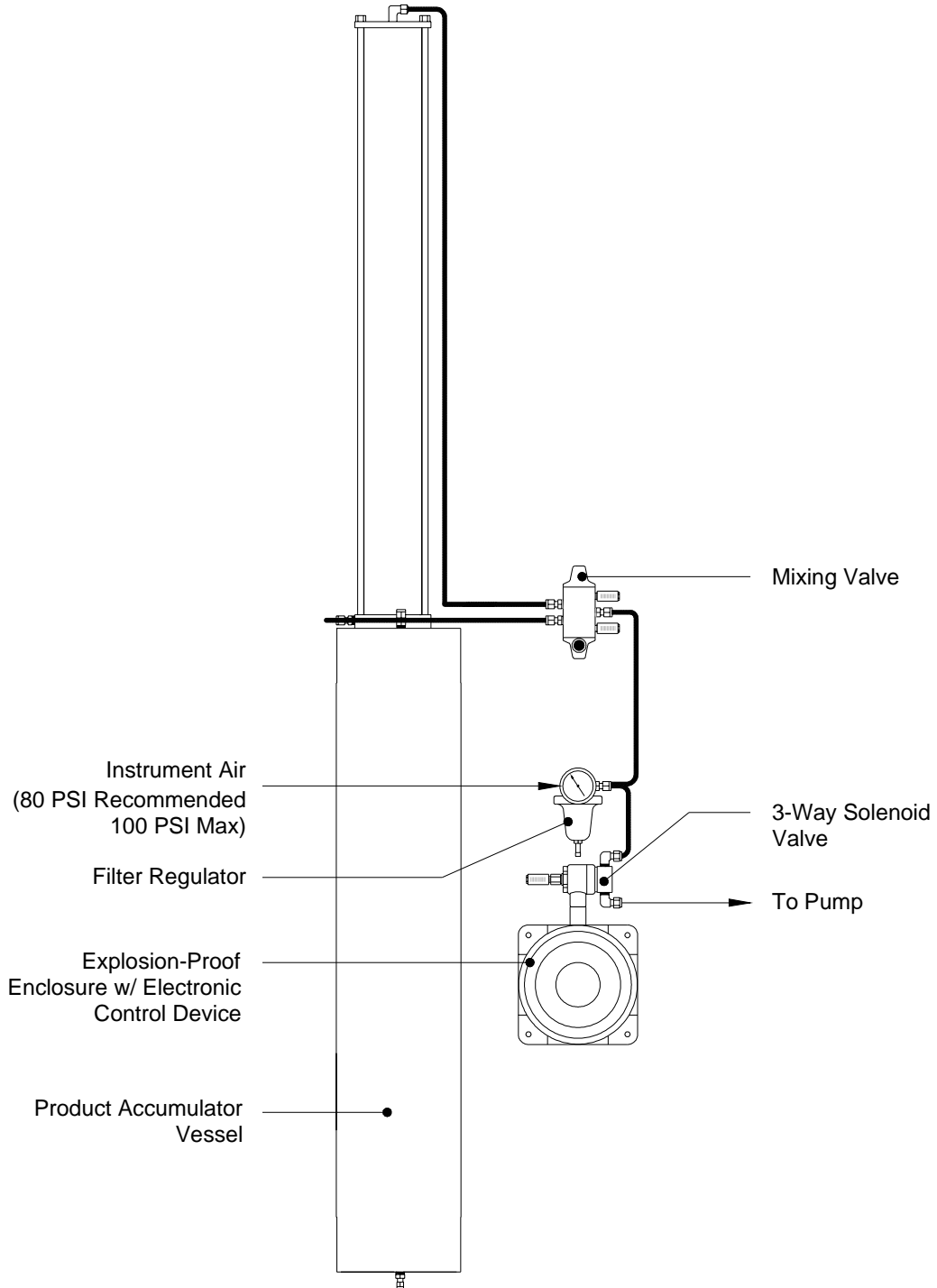

APPENDIX A: ILLUSTRATIONS

Electrical Wiring, Pneumatic-1A

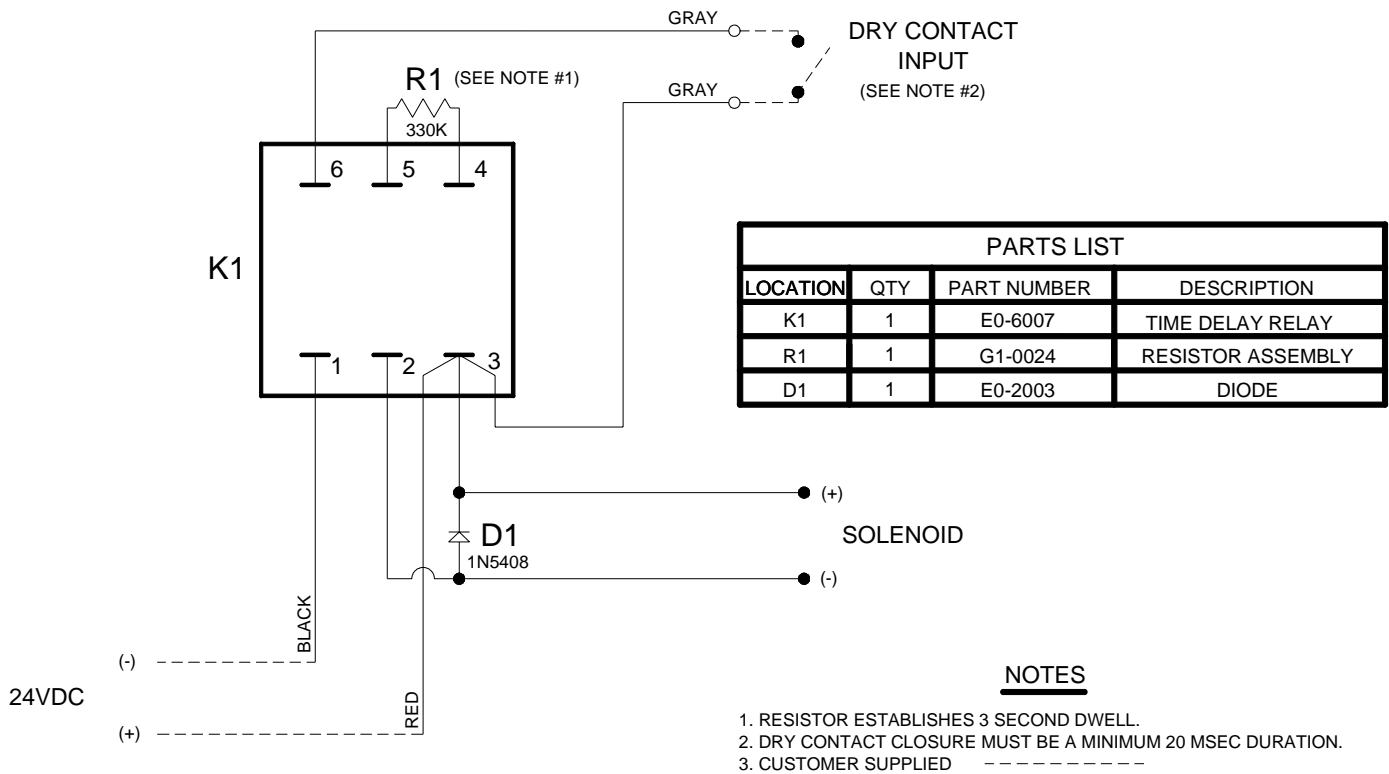



3101 Pollok Drive

Conroe, Texas 77303

800.653.9435

P: 936.788.5593

F: 936.788.5698

Em: Service@yzhq.com

Web: www.yzsystems.com

*YZ Systems, Inc. represents and warrants that for a period of 3 years from receipt of the product: (1) the product will be free from defects in materials and workmanship; and (2) the product will perform substantially in accordance with product manuals, literature, or documentation. Any written or oral information or advice given by YZ representatives, agents, or employees will in no way increase the scope of this warranty. If the product fails to comply with the warranty set forth herein, YZ's entire liability and the customer's exclusive remedy will be replacement of the product(s) or, at YZ's option, YZ's reasonable effort to make the product meet the warranty set forth herein. **YZ disclaims all other warranties, either expressed or implied, including but not limited to, implied warranties or merchantability and fitness for a particular purpose, with respect to the product.** This limited warranty gives you specific legal rights. You may have others, which vary from state to state. **These remedies are not available outside of the United States and Canada.** In no event shall YZ or its suppliers be liable for any damages whatsoever (including, without limitation, damages for loss of profits, business interruption, loss of information, or other pecuniary loss) arising out of the use of or inability to use the product, even if YZ has been advised of the possibility of such damages. Information contained in this document is subject to change without notice and does not represent a commitment on the part of YZ Systems, Inc. All prices quoted are in U.S. dollars, F.O.B. Snyder, Texas. All other product names and/or registered trademarks are the property of their respective holders. YZ support services are subject to YZ's then-current prices, terms, and conditions, which are subject to change without notice. All prices and specifications, if published, are subject to change without notice.*